

MOZA AIR2

User Manual

Contents

■ MOZA Air 2 Overview	1
■ Air 2 Installation	2
• Attaching the Tripod	2
• Installing Batteries	2
• Mounting the Camera	3
• Connecting Camera Control Cable	4
• Installing the Support Rod	4
• Mounting the Riser Plate	5
■ Balance Adjustment	6
• Lock the Roll Axis	6
• Balancing the Camera	6
• Balancing the Tilt Axis	6
• Balancing the Roll Axis	7
• Balancing the Pan Axis	7
■ Buttons and OLED Display	8
• Button Functions	8
• Main Interface	8
• Menu Description	9
■ Features Description	11
• Camera Control	11
• Motor Output	13
• Follow mode,FPV,Sport Gear Mode	14
• Manual Positioning	15
• Button Customization	15
• Inception Mode	15
• Balance Check	16
• Sensor Calibration	17
• Language Switch	18
• User Configuration	18
■ Management	18
• Extension	19
• Smartphone and PC connection	19
• Install the Phone Holder	19
• FirmwareUpgrade	20
■ SPECS	21

MOZA AIR 2 Overview

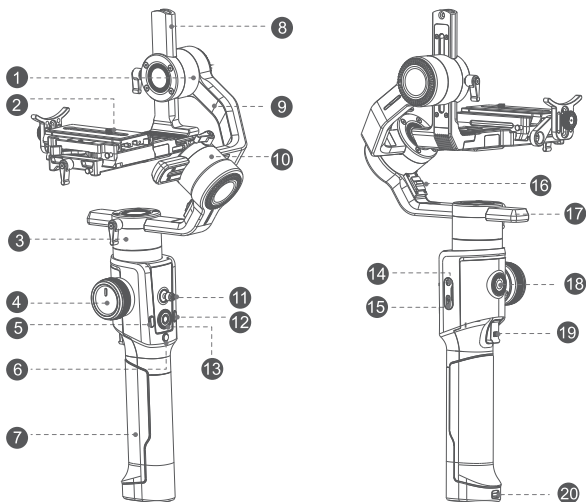

- | | | | |
|--|-----------------|-------------------------------|------------------------|
| 1 Tilt Motor | 6 Power Button | 11 Joystick | 16 Roll Motor Lock |
| 2 Mechanical Memory Quick Release System | 7 Battery Hatch | 12 Fn Button | 17 Pan Arm |
| 3 Pan Motor | 8 Tilt Arm | 13 Dial | 18 3/8" Extension Port |
| 4 Wheel | 9 Roll Arm | 14 DC Input Port | 19 Smart Trigger |
| 5 M Button | 10 Roll Motor | 15 Tune/Firmware Upgrade Port | 20 Battery Hatch Lock |

AIR 2 Installation

Attaching the Tripod

2 screw holes are equipped at the bottom of grip: 1/4" for mini tripod and 3/8" for large accessories like slider and big tripod. Screw the mini tripod, then expand as shown below.

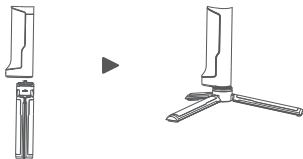

Installing Batteries

⚠ Note: Please pay attention to the battery poles for fear of short circuit.

a. Hold the battery hatch slightly, push the lock downward, slide the hatch as shown below and then release the lock.

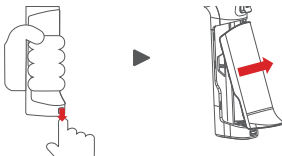

b. Insert the batteries one by one as shown.



c. Cover the battery hatch.

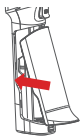

Mounting the Camera

The Air 2 quick release plate is equipped with 2 screws, select an appropriate one according to the camera type. There is no limit to the installing direction of the quick release plate. When mounting the camera, make sure the lens slightly extends beyond the quick release plate in order to reserve extra room for lens support and rod adaptor

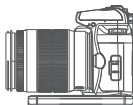

- After mounting the camera onto the quick release plate, loosen the lever A, then slide the quick release plate onto the baseplate. The quick release plate can be installed from both back and forth.
- Please make sure the safety lock 1 and 2 will eject once each, and a rough back and forth balance is reached.

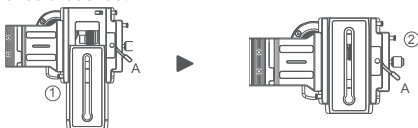

- Press the safety lock 1, the quick release plate will be removed in the direction shown below.

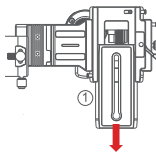

- Press the safety lock 1, slide the plate as shown below, then press the lock 2 when the plate is moved to the end. The quick release plate will be removed in the reverse direction.

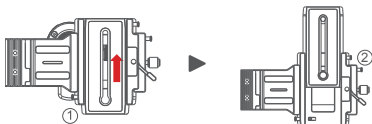

⚠ Note: It is recommended to use the lens support for the best effect.

Connecting Camera Control Cable

4 different control cables are stored in the tool box

- M3C-Mini cable: For cameras with Mini port like Canon 5D3, etc
- M3C-Micro cable: For cameras with Micro port like Canon 5D4, etc
- MCSC-Remote cable: For Panasonic cameras with 2.5mm port like GH3, GH4, etc
- MCSC-Multi cable: For Sony cameras with Multi port like A7s II, A7 III, etc
- MCSC-Multi/C cable: For Sony cameras with Multi port and USB power supply like A7s II, A7 III, etc

Connect the control cable to the CAM CTRL port on the Air 2 gimbal, and then the other end to the control port on the camera. The camera icon will be displayed on the OLED screen. Then parameters adjusting, video recording or photo taking, and follow focus can be directly operated on the gimbal.

⚠ Note:

- For details of different cameras and lenses, please refer to the page 11.
- If USB control is not supported, the camera icon won't display on the screen, please choose your camera control protocol manually.

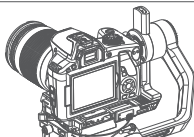

Installing the Support Rod

Please install the rod before using the follow focus.

Take out the rod adaptor, M3x10 screws, Allen wrench first. Fix the adaptor on the front or back of the quick release plate with M3x10 screws, then revolve the support rod into the adaptor.

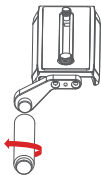

When installed at the left side, please match the stud of the rod adaptor and the screw hole of the support rod, then tighten the support rod counterclockwise.

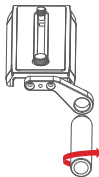

When installed at the right side, please match the screw hole of the rod adaptor and the stud of the support rod, then tighten the support rod clockwise.

⚠ Note: 1. Please install the support rod and rod adaptor according to the position shown above for fear of falling off. 2. Can't assemble 2 support rods together as extending use

Mounting the Riser Plates

The riser plates need to be used in the follow cases:

- The camera is too short to balance the tilt axis
- The lens is too short to install the follow focus
- The follow focus needs to be installed for zoom

⚠ Note: If the rod adaptor has been installed before mounting the riser plates, please remove the adaptor first.

Fix the riser plates in the screw holes on both ends of the quick release plate, then fix the other quick release plate onto the riser plates in the same way.

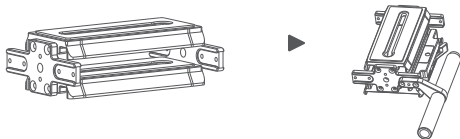

There are also screw holes on the riser plates for installing the rod adaptor.

Balance Adjustment

⚠ Note: In order to make the adjustment easier, please refer to the balance check function of Air 2 on page 16.

Lock the Roll Axis

Move the roll motor lock to the lock end, rotate the roll arm to the position shown below, then the roll arm will automatically lock.

⚠ Note: If the roll arm locks in the position overlapping the pan arm, please unlock the roll motor first)

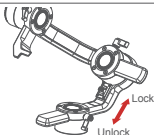

Balancing the Camera

- Mount the camera onto the Air 2, release hands to check if the camera is top or bottom heavy.
- If the camera is bottom heavy, loosen the knob to slide the quick release baseplate forwards until the lens points forward.
- If the camera is top heavy, loosen the knob to slide the quick release baseplate backwards until the lens points forward.
- Tighten the knob.

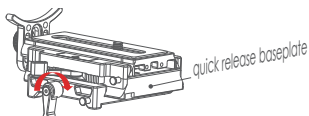

Balancing the Tilt Axis

- Rotate the camera so that the lens is pointing upward, release hands to check the direction in which the camera swings.
- Loosen the knob 1 on the tilt motor to slide the tilt arm 2 until the camera stays still without tilting it up or down.
- Tighten the knob 1.

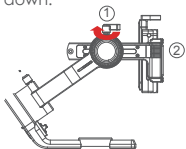

Balancing the Roll Axis

- Move the roll motor lock switch to the unlock end.
- Release hands to observe the direction in which the roll axis swings.
- Loosen the roll axis knob 1 to slide the roll arm 2 until the roll arm 2 stays still.
- Tighten the knob 1.

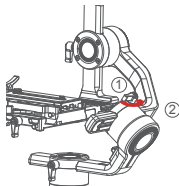

Balancing the Pan Axis

- Grab the Air 2 horizontally, make the pan arm level. Release hands to check the direction in which the camera swings.
- Loosen the knob 1 on the pan motor. Move the pan arm 2 leftwards or rightwards until it keeps level.
- Tighten the knob 1.

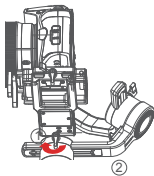

⚠ Note: If the balance of the pan axis is not adjusted properly, the pan axis may become hot, and the inception mode cannot be used properly.







Buttons and OLED Display

Button Functions:

Button	Operation	Function	Customizable Function						Menu
Trigger	1 X	—	N/A	Focus	Photo	—	—	—	The same
	2 X	Re-Center	N/A	Re-Center	Selfie	—	—	—	The same
	3 X	Selfie	N/A	Re-Center	Selfie	—	—	—	The same
	Hold	Pan-Tilt Follow	N/A	Pan-Tilt Follow	All lock	Sport gear mode	FPV mode	—	The same
Power Button	1 X	Video recording	—	—	—	—	—	—	The same
	2 X	Take photo	—	—	—	—	—	—	The same
	3s	ON/OFF	—	—	—	—	—	—	The same
Wheel	Turn	Focus motor 1	Focus motor	Focus motor 2	E-focus	Tilt axis	Roll axis	Pan axis	The same
M Button	1 X	Switch wheel modes	—	—	—	—	—	—	The same
Fn Button	1 X	Sport gear mode	—	—	—	—	—	—	The same
	2 X	Inception mode	—	—	—	—	—	—	The same
	3 X	FPV mode	—	—	—	—	—	—	The same
	3s	Auto tune	—	—	—	—	—	—	The same
Joystick	Push Up-Down	Move the tilt axis	Tilt axis	Roll axis	Pan axis	—	—	—	The same
	Push Left-Right	Move the pan axis	Tilt axis	Roll axis	Pan axis	—	—	—	The same
Top	1 X	TV	—	—	—	—	—	—	Option-up
	2 X	Tilt follow	—	—	—	—	—	—	—
Down	1 X	AV	—	—	—	—	—	—	Option-down
	2 X	Pan follow	—	—	—	—	—	—	—
Left	1 X	ISO	—	—	—	—	—	—	Return
	2 X	Roll follow	—	—	—	—	—	—	—
Right	1 X	Enter/Exit preview	—	—	—	—	—	—	Confirm/Next menu
Menu Button	1 X	Enter the menu	—	—	—	—	—	—	The same
	3 X	Language	—	—	—	—	—	—	The same
	3s	Sleep/wake up	—	—	—	—	—	—	The same
Dial	Turn	Follow speed	—	—	—	—	—	—	Adjust relevant
Combo	Menu+Power	Upgrade mode	—	—	—	—	—	—	—

Main interface

A: Smart wheel working modes

-  Controlling external follow focus motor 1
-  Controlling external follow focus motor 2
-  Electronic follow focus
-  Controlling the tilt axis
-  Controlling the roll axis
-  Controlling the pan axis

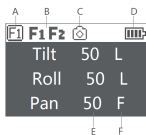

B: Focus motor connection status. Icon will be displayed after

connection, otherwise it won't be displayed. Up to two focus motors can be connected at the same time.

C: Camera connection status. Icon will be displayed after USB connection, otherwise it won't be displayed.

D: Battery level. Each grid represents 25% battery level. When the battery is empty, please charge the battery in time.

E: Follow speed value: 0-100. Turn the dial to adjust the value

F: Follow status

- L: Lock. The axis locks and doesn't follow.
- F: Follow. The axis follows.
- Q: Sport Gear Mode

Menu Description

L1	L2	L3	L4	L5	Value	Function	
camera		Shutter Cable			*	set the connection type to universal shutter cable	
		MCSC-Multi			*	set the connection type to Sony-Multi port	
		MCSC-Multi/C			*	set the connection type to Sony-Multi port and power supply	
		MCSC-Remote			*	set the connection type to Panasonic-Remote port	
		M3C-USB			*	set the connection type to USB port	
	ISO				32--106400	Set the camera ISO	
	TV				30--1/8000	Set the camera shutter	
		AV			F1--F22	Set the camera aperture	
motor	switch				? /ok	turn on/off motor	
					? /ok	tuning/tuned	
	power	autotune					
			level	ultra light	*	set motor level to the minimum	
				light	*	set motor level to light	
				medium	*	set motor level to medium	
				heavy	*	set motor level to heavy	
		ultra heavy	*	set motor level to ultra heavy			
	custom	tilt			0-100	set tilt motor power	
		roll			0-100	set roll motor power	
		pan			0-100	set pan motor power	
	filter	tilt			0-100	set tilt motor filter	
		roll			0-100	set roll motor filter	
		pan			0-100	set pan motor filter	
	follow	switch	tilt			on/off	enter/exit tilt follow mode
			roll			on/off	enter/exit roll follow mode
			pan			on/off	enter/exit pan follow mode
		speed	tilt			0-100	set the following speed of tilt motor
			roll			0-100	set the following speed of roll motor
			pan			0-100	set the following speed of pan motor
deadband		tilt			0-100	set the following initiation angle of tilt motor	
		roll			0-100	set the following initiation angle of roll motor	
		pan			0-100	set the following initiation angle of pan motor	
gimbal	joystick	function	left-right			tilt/rol/pan	move the joystick left/right to control the tilt/roll/pan rotation
			up-down			tilt/rol/pan	move the joystick up/down to control the tilt/roll/pan rotation
		sensitivity	left-right			0-100	set sensitivity level of left-right movement
			up-down			0-100	set sensitivity level of up-down movement
		habits	left-right			+/-	set the control habit of joystick left/right movement
			up-down			+/-	set the control habit of joystick up/down movement
		wheel	function	focus-1	*	control the external focus motor 1	
				focus-2	*	control the external focus motor 2	
				focus-e	*	control the electronic focus	
				tilt	*	control the pan axis	
	roll			*	control the tilt axis		
	pan			*	control the roll axis		
	sensitivity				0-100	wheel sensitivity	
	habits				+/-	set the control direction of wheel rotation	
	operation	hold	none	*	none		
			follow	*	enter pan-tilt follow mode		
			lock	*	enter all lock mode		
			quick	*	enter sport gear mode		
			FPV	*	enter FPV mode		
		click	none	*	none		
shutter			*	take photo			
focus			*	auto focus			
double-click		none	*	none			
		re-center	*	re-center			
triple-click	selfie	*	rotate the gimbal 180° for selfie				
	none	*	none				
	re-center	*	re-center				
		selfie	*	rotate the gimbal 180° for selfie			

L1	L2	L3	L4	L5	Value	Function	
gimbal	operation	dial	habits		+/-	rotate the dial clockwise to increase/decrease value	
	autotune				? /ok	auto tune	
advanced	balance	clk				check the balance state of camera	
		IFocus	F1	switch		? /ok/err	turn on/off the focus motor 1
	set A				? /ok/err	set the point A of focus motor 1	
	set B				? /ok/err	set the point B of focus motor 1	
	Clear AB				? /ok/err	Clear the calibration information	
	Guidance				>	Enter the guidance mode	
	F2	switch		? /ok/err	turn on/off the focus motor 1		
		set A		? /ok/err	set the point A of focus motor 1		
		set B		? /ok/err	set the point B of focus motor 1		
		Clear AB		? /ok/err	Clear the calibration information		
		Guidance		>	Enter the guidance mode		
	Dolly Zoom			>	Enter the dolly zoom mode		
	inception	speed			0-100	set the rotation speed of inception mode	
	motion sensin	switch	tilt		? /on/off	turn on/off the motion control of tilt axis	
roll				? /on/off	turn on/off the motion control of roll axis		
pan				? /on/off	turn on/off the motion control of pan axis		
tracking	speed			0-100	set the rotation speed of motion control		
manual pos	tilt			on/off	set the max speed of tracking		
	roll			on/off	turn on/off the manual positioning of tilt axis		
	pan			on/off	turn on/off the manual positioning of roll axis		
calibration	gyro			? /ok	turn on/off the manual positioning of pan axis		
	acc			? /ok	calibrating/calibrated the gyroscope		
	angle offset	tilt			0-100	calibrating/calibrated the accelerometer	
		roll			0-100	set the offset value of tilt axis	
		pan			0-100	set the offset value of roll axis	
general	language	English			*	set the offset value of pan axis	
		中文			*	switch display language to English	
	config	config1	save			? /ok	switch display language to Chinese
			load			? /ok	save to configuration 1
		config2	save			? /ok	load configuration 1
			load			? /ok	save to configuration 2
		config3	save			? /ok	load configuration 2
	load			? /ok	save to configuration 3		
	reset				? /ok	load configuration 3	
	about				? /ok	restore default parameter settings	
						device name and firmware information	

Menu type introduction:

If there is a ">" mark at the right side of the selected item, press the dial right button for the next menu.

If the selected item has a "[]" and contains a number, rotate the dial to adjust its value.

If the selected item has a "()" and contains an option, press the right button to switch among options.

Notes:

- If there is a "*" at the right side of one item, the current list is the final option, press the dial right button to launch it.
- If the selected item and other items in the menu list don't have any marks, press the dial right button to launch the option once. ">" is displayed during the process. "OK" is displayed after the process is completed, and "ERR" is displayed if the option fails.



3. Filtering parameters: When the motor vibrates with high frequency, the value should be turned down. When the motor vibrates with low-frequency, the value should be increased.
4. The manual positioning function has lower priority than the following function. When using manual positioning function normally, following function of the axis should be turned off.

Features Description

Camera Control

The Air 2 can support camera video recording, photo taking and electronic focus control. Please refer to the compatibility list for more details

(* Please set the lens to "MF" mode)

Brand	Model	Select	Cable	Shutter	Record	ISO	TV	AV	Auto Focus	Focus Control	Power Supply	
CANON	EOS R	M3C-USB	M3C-Micro+ Micro to Type-C Adapter (optional)	√	√	√	√	√	√	√	—	
	EOS RP			√	√	√	√	√	√	√	—	
	EOS 6D Mark II		M3C-Mini	* √	√	√	√	√	√	√	√	—
	EOS 6D			* √	√	√	√	√	√	√	√	—
	EOS 60D			* √	√	√	√	√	√	√	√	—
	EOS 70D			* √	√	√	√	√	√	√	√	—
	EOS 77D			* √	√	√	√	√	√	√	√	—
	EOS 80D			* √	√	√	√	√	√	√	√	—
	EOS SD2			* √	√	√	√	√	√	√	√	—
	EOS SD3			* √	√	√	√	√	√	√	√	—
	EOS 800D			* √	√	√	√	√	√	√	√	—
	EOS 5D Mark IV			M3C-Micro	* √	√	√	√	√	√	√	√
	EOS 200D II		* √		√	√	√	√	√	√	√	—
	EOS M50		* √		√	√	√	√	√	√	√	—
	EOS M5		MCSC-C1	C1 Shutter Cable (optional)	√	—	—	—	—	—	—	—
SONY	Alpha 7S	M3C-USB	M3C-Micro	—	√	√	√	√	√	√	√	
	Alpha 7R			—	√	√	√	√	√	√	√	
	Alpha 6300			—	√	√	√	√	√	√	√	
	Alpha 6400			—	√	√	√	√	√	√	√	
	Alpha 6500			—	√	√	√	√	√	√	√	
	Alpha 7S II			—	√	√	√	√	√	√	√	
	Alpha 7R II			—	√	√	√	√	√	√	√	
	Alpha 7 II			—	√	√	√	√	√	√	√	
	Alpha 7R III			—	√	√	√	√	√	√	√	
	Alpha 7R III			—	√	√	√	√	√	√	√	
	DSC-RX100M3	MCSC-Multi	MCSC-Multi	—	√	√	—	—	—	√	√	
	DSC-RX100M4			—	√	√	√	√	√	√	√	
	DSC-RX100M5			—	√	√	√	√	√	√	√	
	Alpha 7S			√	√	—	—	—	—	√	√	
	Alpha 7R	√	√	—	—	—	—	√	√			
	Alpha 6300	√	√	—	—	—	—	√	√			
	Alpha 6400	√	√	—	—	—	—	√	√			
	Alpha 6500	√	√	—	—	—	—	√	√			
	Alpha 7S II	√	√	—	—	—	—	√	√			
	Alpha 7R II	√	√	—	—	—	—	√	√			
Alpha 7 II	MCSC-Multi/C	MCSC-Multi/C	√	√	—	—	—	√	√			
Alpha 7R III			√	√	—	—	—	√	√			
Alpha 7R III			√	√	—	—	—	—	√	√		
DSC-RX100M3			√	√	—	—	—	—	√	√		
DSC-RX100M4	√	√	—	—	—	—	√	√				
DSC-RX100M5	√	√	—	—	—	—	√	√				
Panasonic	DMC-G7K/GK	MCSC-Remote	MCSC-Remote	√	√	—	—	—	√	—	—	
	DMC-G85GK			√	√	—	—	—	√	—	—	
	DMC-GH3			√	√	—	—	—	√	—	—	
	Lumix GH4			√	√	—	—	—	√	—	—	
	DC-S1GK-K			√	√	—	—	—	√	—	—	
	Lumix GH5			√	√	√	√	√	√	√	√	√
DC-GH5SGK-K	√	√	√	√	√	√	√	√	√			
Nikon	Z6	M3C-USB	M3C-Micro+ Micro to Type-C Adapter (optional)	√	√	√	√	√	√	√	—	
	Z7			√	√	√	√	√	√	√	—	
	D850		M3C-Micro	√	√	√	√	√	√	√	—	
FUJIFILM	X-T2	MCSC-C1	C1 Shutter Cable (optional)	√	√	—	—	—	√	—	—	
	X-T3			√	√	—	—	—	√	—	—	
	X-T30			√	√	—	—	—	√	—	—	
	X-T30			√	√	—	—	—	√	—	—	

Note: please refer to the official website for the latest camera control list.

Operation Steps:

- a. Long press the center button to enter the menu, refer to the compatibility list to select the correct camera type.

b. Refer to the list to choose and connect the camera control cable. Connect the Mini-USB end of the control cable to the control port of AirCross 2. Connect the other end to the corresponding control port of the camera.

c. You can achieve recording by clicking the menu button one time and taking photos by clicking menu button twice after selecting the camera type and connecting the camera control cable.

⚠ Note:

1. Cameras equipped with Micro USB 3.0 interface, such as the Nikon D850, can be normally controlled by half plugging the M3C-Micro cable.



2. After plugging the camera control cable, please operate the camera according to the prompts on the camera screen, otherwise the camera control function may not work properly.

- Start/Stop: Press power button once
- Shoot photos: Press power button twice
- Adjust shutter: Press the up button of the dial (TV)
- Adjust aperture: Press the down button of the dial (AV)
- Adjust ISO: Press the left button of the dial (ISO)

When adjusting camera parameters, press the corresponding button and the screen will display the value, then turn the dial to adjust the value. After the adjustment is completed, press the corresponding button again to turn off the adjustment of camera parameters.

- Turn on/ off preview: press the right button of the dial to turn on or off live preview.



⚠ Note:

1. Only when start camera settings can turn the dial adjust parameters. Under the default state, turn the dial would adjust the follow speed. Please refer to page 14 to get more follow modes information.

2. Some cameras with sensor, like Sony A7S2 will shut down the screen and switch to viewfinder for preview, if there is obstruction before the viewfinder. Set preview setting to screen

Motor Output

The payload of Air 2 is from 300g to 4200g. Different payload requires different motor power to achieve the best stability. There are three methods for adjusting the output of the motor:

Auto-tuning operation method:

- Install the camera and adjust the balan
- Unlock all motor loc
- Turn on the stabilizer, long press the center button to enter the menu, sele 'Gimbal' > 'Motor' > 'Power' > 'Auto-tune'
- During the auto-tuning, the stabilizer will vibrate automatically to match the most suitable output value. Wait for about 5 seconds, the stabilizer stops shaking, and the auto-tuning completes.

camera >	motor >	switch	autotune
gimbal >	follow >	power >	level >
advanced >	operation >	filter >	custom >
general >			

Set the output gear:

Factory default presets 5 groups of motor output values, which are suitable for cameras of different weight levels.

Customize the output value of each motor:



The users can customize the output value of each motor to reach more precise control of the motor output. The adjustment range is 0 to 100.

Note:

- Under the camera lens combination of the limit, the auto-tuning function may not accurately calculate the appropriate output value. Please manually adjust the motor output according to the situation.
- If the motor output is too low, the video is not stable enough; if the motor output is too high, it will cause high-frequency vibration of the stabilizer.
- When the motor output is at the critical value, the stabilizer will not vibrate in the upright state, but it will vibrate in the forward or inverted state. Please reduce the motor output moderately.

FPV, Sport Gear Mode

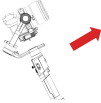
When the follow function is enabled, the camera will follow the movement of the gimbal. Users can enable the follow mode of each axis through dial buttons and turn the dial to adjust the following speed, which can be also enabled in the menu.

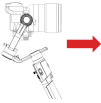
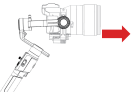
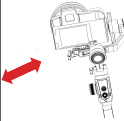
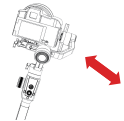
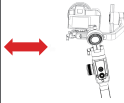
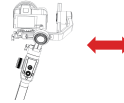
Follow Mode Switch	Example 1	Example 2
Enter the tilt follow		
Exit the tilt follow		
Enter the roll follow		
Exit the roll follow		

⚠ Note:

1. The Air 2 is in pan follow mode by default.
2. In addition to controlling the follow mode by the switches of each axis independently, follow modes can be also enabled by the trigger, please refer to Page 8 'Button Functions' for more details.
3. The angle of the roll follow is 45°. For a larger following angle, please triple click the left button to enter the FPV mode to achieve 360° follow of three axes.
4. If faster following speed is required, please click the right button to enter the sport gear mode. (Currently only supports the pan axis)

Manual Positioning

Manual positioning is used to quickly adjust the direction of the camera. When the function of manual positioning is enabled, the camera orientation can be adjusted by hand which will not automatically return to the initial position. The adjustment speed is faster than using the joystick or the following mode. The manual positioning of the tilt axis is enabled by default on the Air 2. Manual positioning of the roll and pan axes can be enabled in the menu.

camera >	balance chk	tilt [off]	tilt [on]
gimbal >	iFocus >	roll [off]	roll [off]
advanced >	inception >	pan [on]	pan [on]
general >	manual pos >		

⚠ Note: The follow function has higher priority than manual positioning. When the follow function of any axis is on, the manual positioning function cannot be used. Only after the follow function is off, the manual positioning can be used normally.

Button Customization

Button Customization is used to specify the function, sensitivity and operation direction of each button according to the user's habits.

For Example:

By default, moving the joystick up and down controls the tilt axis rotation. It can be changed to control the roll or pan axis rotation by customizing;

By default, moving the joystick left and right controls the pan axis rotation. It can be changed to control the tilt or roll axis rotation by customizing.

camera >	motor >	joystick >	function >	left-right [pan]
gimbal >	follow >	wheel >	sensitivity >	up-down [tilt]
advanced >	operation >	trigger >	habits >	
general >		dial >		

The higher the sensitivity of the button, the more sensitive and faster the control is. If you change the 'custom' to -, the direction of operation will be opposite. For more button customization, please refer to Page9 Menu Description.

Inception Mode

The Inception Mode is used to control the camera to rotate in the roll direction for shooting upside down and rotating footages. In the main interface, triple click the right button to enter the Inception Mode. After entering the Inception Mode, the camera lens is vertically up and each axis automatically follows.

Button Definition for Inception Mode:

- Turn the joystick left or right: the gimbal turns to left or right, when

release or turn to a specified angle, the gimbal stops.

- Turn the dial: adjust the rotation speed
- Press the left button on the dial once: the gimbal rotates to the left automatically. If the gimbal is rotating, press once to stop.
- Press right button on the dial once: the gimbal rotates to the right automatically. If the gimbal is rotating, press once to stop.
- Press up/down button on the dial: select rotation angle
- Normal: gimbal rotates and does not stop automatically
- 180: the gimbal rotates 180° and stops automatically.
- 360: the gimbal rotates 360° and stops automatically.

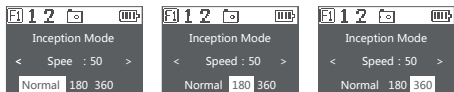

Triple click the right button again to exit the Inception Mode.

Balance Check

The gimbal can check the balance status of tilt and roll axis automatically and instruct users to make the correct adjustment.

- Attach a tripod to the gimbal, turn on the gimbal and place it on a horizontal tabletop.
- Enter the menu, select advanced>balance chk, the gimbal begins to check the balance adjustment.



- When balance check is completed, the balance status of each axis will be displayed on the screen, direction guide will be also displayed if the adjustment is needed.
- 'C' means quick release plate, 'T' means tilt axis, 'R' means roll axis, then start the adjustment according to the screen prompts.
- When adjustment is completed, press the right button and check it again until the gimbal is well balanced.

⚠ Note:

- Balance check can be only used with the tilt and roll axis, the pan axis balance can't be checked. Be sure that the motor lock has been released when using balance check.
- Motors turned off after balance check, please long press 'menu' button to start the gimbal

Sensor Calibration

● Gyroscope Calibration

Turn on the gimbal and leave it quietly for about 5 minutes, the gyroscope calibration is required when the gimbal drifts obviously.

The steps are as follows:

- Turn on the gimbal (long press the power button)
- Turn off the motors (double press the power button/enter the menu, select gimbal>motor>switch, set 'off')
- Leave the Air 2 on the table and don't shake it or the desktop.
- Enter the menu, select advanced>calibrate>Gyro cali and press the dial right button, wait about 5 seconds, when the '?' changes to 'OK', the calibration is completed.

camera >	iFocus >	gyro	gyro ok
gimbal >	inception >	acc	acc
advanced >	manual pos >	angle offset >	angle offset >
general >	calibration >		

● Accelerometer Calibration

Turn on the gimbal and there is no obvious drift, the accelerometer calibration is required when the camera doesn't keep level. The steps are as follows:

- Turn on the gimbal (long press the power button)
- Turn off the motors (double press the power button/enter the menu, select gimbal>motor>switch, set 'off')
- Leave the L-shaped quick release plate on the horizontal table. Avoid the bottom screw and keep the Air 2 at static position. Do not shake the it or tilt it. (or mount the camera to refer to its level)
- Enter the menu, select advanced>calibrate>Acc cali, and press the dial right button to enter calibration. Wait about 5 seconds, when the '?' changes to 'OK', the calibration is completed.

camera >	iFocus >	gyro	gyro
gimbal >	inception >	acc	acc ok
advanced >	manual pos >	angle offset >	angle offset >
general >	calibration >		

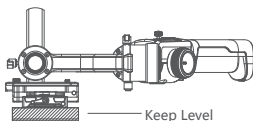

Note:

- Please keep the gimbal stationary during the calibration, any shaking will cause the calibration to deviate.
- Any drastic shaking might cause 'err' shown on the screen, please calibrate again.
- Do not arbitrarily perform calibration operations while it is not necessary.

● Offset

In case of emergency shooting, the camera cannot be leveled and there is no time for sensor calibration, the camera can be adjusted to a horizontal state by offset.

- Turn on the gimbal and the camera level, check the offset of the tilt and yaw axis.
- Enter the menu, select advanced>calibrate>offset, select an axis that is not horizontal, and then turn the dial to adjust the fine adjustment value of the axis until the camera completely keeps level.

camera >	iFocus >	gyro	tilt [0]	tilt [1]
gimbal >	inception >	acc	roll [0]	roll [0]
advanced >	manual pos >	angle offset >	pan [0]	pan [0]
general >	calibration >			

! Notes:

- The offset can only adjust the angle of each axis within the range of about $\pm 5^\circ$, if there is too much offset, the camera cannot be completely leveled.
- Offset is only a temporary solution, after shooting, accelerometer calibration is still needed.
- The parameters of the offset will not be saved and will become invalid after restart.

Language Switch

The Air 2 supports both Chinese and English. After turning on the gimbal, users can switch language in the menu.

camera >	language >	English	English *
gimbal >	config >	中文 *	中文
advanced >	about		
general >			

User Configuration Management

The Air 2 can save 3 groups of user data like camera type, motor output, button operations and other parameters, so users can retrieve relevant parameters previously used and avoid trouble of setting parameters each time when changing the camera.

camera >	language >	config1 >	save
gimbal >	config >	config2 >	load
advanced >	about	config3 >	
general >		reset	

When configuration data is confusing, users can select "restore configuration" to clear all previous configuration data.

Smartphone and PC Connection

The Air 2 is equipped with BLUETOOTH 4.0 and can be connected with smartphones. Users can set parameters, shot time-lapse video, upgrade firmware and make other operations via the MOZA Master App. With a Type-C USB interface, the Air 2 is able to be connected to a computer. Users can set parameter, upgrade firmware and make other operations via the MOZA Master software.

Download Link: <https://www.gudsen.com/moza-Air 2>

⚠ Note:

1. The MOZA Master supports iOS, Android, Windows and MacOS
2. Before using the MOZA Master on computer, please install the driver first, otherwise the computer cannot recognize the Air 2
3. Smart phones cannot directly pair with the Air 2 via Bluetooth, MOZA Master App must be used to connect your phone with the Air 2

Install the Phone Holder

Install the phone on top of the camera. Operate object tracking through App.

- a. Fix the phone holder to the hot shoe connector on the top of the camera
- b. Place the phone horizontally in the phone holder
- c. Open the App. Enter the object tracking feature. Adjust the phone angle. Make the phone framing as consistent as possible with the camera framing.



In addition to being mounted on the top of the camera for object tracking, the phone holder can also be used to fasten the phone to tripod head for mimic motion control.

Firmware Upgrade

Upgrade via computer:

- a. Turn off the gimbal.
- b. Long press the Menu, then press the power button with the other hand until the prompt 'Boot Mode' appears on the screen.
- c. Connect the gimbal to the computer with a USB Type-C cable.
- d. The software will automatically identify the device and load the firmware. Press the 'Upgrade' button and wait for about 30s.

e.Restart the gimbal after the upgrade.

Upgrade via App:

a.Turn off the gimbal.

b. Long press the Menu, then press the power button with your another hand until the prompt "Boot Mode" appears on the screen.

c.Start App, press Bluetooth to search for Air 2 device and connect.

d. The App will automatically enter the firmware upgrade interface, please wait for the firmware download to complete, press the 'upgrade' button and wait for about 5 minutes.

e. During the upgrade process, 'upgrading' will be displayed on the gimbal screen, and ' upgrade success' will be displayed on the screen after the upgrade is completed, and then air 2 can be restarted.

Specifications

Air 2	
Payload Range	0.3kg~4.2kg
Dimension	230*240*470 mm
Tilt Camera Tray Dimension	110 mm
Roll Camera Tray Dimension	100 mm
Pan Mechanical Endpoint Range	360°
Roll Mechanical Endpoint Range	360°
Tilt Mechanical Endpoint Range	+180°~-95°
Battery Type	INR18650D250
Battery Capacity	2500 mAh
Working Voltage	15.2V
Static Current	150mA
Communication	BLUETOOTH 4.0 BLE
	2.4G
	USB
Camera Control Port	Mini USB 5V 1A
Dummy Battery Port	DC2.0mm 7.8V 1A
Accessory Power Supply Port	DC5.5mm 12V 2A
External Power Supply Port	DC5.5mm 14.8V 3A
Temperature	0--50 C

Contacts



Official Website



Sina Weibo



WeChat



Instagram



Twitter



Facebook



YouTube

GUDSEN

INVENTED FOR VIDEO

Shenzhen Gudsen Technology Co., Ltd

Web: www.gudsen.com